



**Standards:**

1. It is designed and manufactured according to YY0469-2004 "Technical Requirements for Medical Surgical Masks" and GB2626-2006 "Respiratory Protective Equipment Self-Suction Filter Anti-Particle Respirator". At the same time, it also refers to the advanced design concepts of similar international equipment (such as the American TSI company), based on the principle of "European standard EN1822-3: 1998 single-sheet filter material test", but it is suitable for the test status of domestic related industries
2. GB / T 32610-2016 "Technical Specifications for Daily Protective Masks"
3. GB / T 19082-2009 "Technical requirements for medical disposable protective clothing"
4. GB / T 19083-2010 "Technical Requirements for Medical Protective Masks"
5. GB 24539-2009 General technical requirements for protective clothing and chemical protective clothing
6. YY / T 0969-2013 "Standard for disposable medical masks"

**Standard Requirement:**

Using sodium chloride particles to detect KN filter elements, and use dioctyl phthalate or equivalent oil particles (or paraffin oil) to detect KP filter elements.

Test according to 6.3

During the test, the filtration efficiency of each sample should always meet the requirements of Table 2

Tags : [GLE-20](#) , [Particulate filtration efficiency tester](#)



KN95	95.0%	
KN100	99.97%	Not Siut
KP90		90.0%
KP95		95.0%
KP100	Not Suit	99.97%

#### Specifications:

1. Filtration efficiency detection flowmeter range: (10 ~ 100) L / min, accuracy level 2.5
2. Filtration efficiency detection range: (0.001 ~ 999)%.
3. Filtering efficiency sampling frequency: 1-9999 times / min can be set arbitrarily.
4. Filtration efficiency Particulate concentration: (0.001-200) mg / m<sup>3</sup>.
5. Differential pressure sensor range: 0 ~ 1000pa
6. Counting median diameter: salt particles (0.075 ± 0.02) μm, oil particles (0.185 ± 0.02) μm. Geometric standard deviation of particle size distribution: salt particles ≤ 1.86, oil particles ≤ 1.60. Dynamic detection range: 0.001-100 mg / m<sup>3</sup>, accuracy 1%.
7. Test area: 100cm<sup>2</sup>.
8. Aerosol: NaCl (optionally with DOP, DEHS, paraffin oil, corn oil).
9. Aerosol concentration: 12-20mg / m<sup>3</sup> (NaCl), 50-200mg / m<sup>3</sup> (DOP).
10. The system contains two independent aerosol generators: oily and salty aerosol generators containing two particle counting sensors, one particle concentration sensor and one particle generator
11. Power: AC220V 50Hz(120V/60Hz can be customized)

#### GLE-20 Characteristics:

1. The oil and salt two-in-one test and the two sets of test hardware systems are completely independent. The test does not interfere with each other to ensure the accuracy of the oil and salt test.



6. Configure temperature and humidity sensor, real-time display of ambient temperature and humidity (temperature and humidity requirements:  $25\text{ }^{\circ}\text{C} \pm 5\text{ }^{\circ}\text{C}$ ,  $30\% \text{ RH} \pm 10\% \text{ RH}$ ).
7. Equipped with glass rotor flowmeter, vacuum pump and gas electromagnetic flowmeter.
8. Control system: touch-screen computer and test software have been configured to automatically test gas concentration and filtration efficiency, save, output, query, copy and export test data, support A4 paper printing and small bill printing test results



公司名称: LISUN                      公司地址: Shanghai  
 样品名称: 12306                      样品编号: 002  
 测试人员:                              测试标准: GB2626  
 测试时间: 2020/06/06 17:48:08      报告时间: 2020/06/06 17:50:40

测试条件			
测试面积:	100cm <sup>3</sup>	气溶胶:	油性 / 33.96 mg/m <sup>3</sup>
采样时间:	90	采样间隔:	2
测试流量:	94.80 L/min	气流阻力:	126.0Pa
温度 (°C):	29.00°C	湿度 (%RH):	84.40%

测试数据				
粒径	上游颗粒数	下游颗粒数	过滤效率 (%)	穿透率 (%)
0.3 μm (PFE)	70914.00	573.00	99.19	0.81
0.5 μm	15635.00	79.00	99.49	0.51
1.0 μm	3320.00	3.00	99.91	0.09
2.5 μm (BFE 参照)	230.00	0.00	100.00	0.00
5.0 μm	2.00	0.00	100.00	0.00

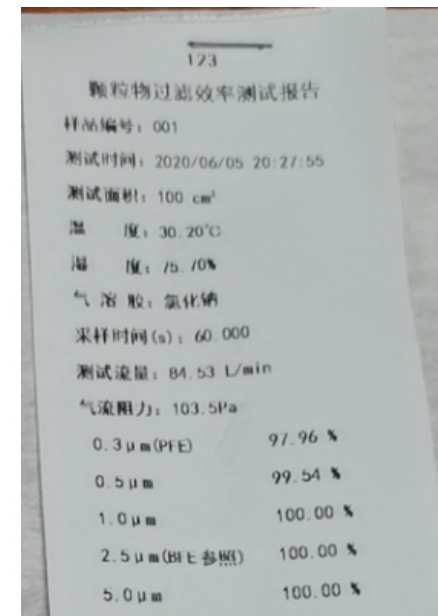

检测员: \_\_\_\_\_ 审核人: \_\_\_\_\_ 复核人: \_\_\_\_\_



Designation: F2299/F2299M – 03 (Reapproved 2017)

# Standard Test Method for Determining the Initial Efficiency of Materials Used in Medical Face Masks to Penetration by Particulates Using Latex Spheres<sup>1</sup>

This standard is issued under the fixed designation F2299/F2299M; the number immediately following the designation indicates the year of original adoption or, in the case of revision, the year of last revision. A number in parentheses indicates the year of last reapproval. A superscript epsilon ( $\epsilon$ ) indicates an editorial change since the last revision or reapproval.

## 1. Scope

1.1 This test method establishes procedures for measuring the initial particle filtration efficiency of materials used in medical facemasks using monodispersed aerosols.

1.1.1 This test method utilizes light scattering particle counting in the size range of 0.1 to 5.0  $\mu\text{m}$  and airflow test velocities of 0.5 to 25 cm/s.

1.2 The test procedure measures filtration efficiency by comparing the particle count in the feed stream (upstream) to that in the filtrate (downstream).

1.3 The values stated in SI units or in other units shall be regarded separately as standard. The values stated in each system must be used independently of the other, without combining values in any way.

1.4 The following precautionary caveat pertains only to the test methods portion, Section 10, of this specification. *This standard does not purport to address all of the safety concerns, if any, associated with its use. It is the responsibility of the user of this standard to establish appropriate safety and health practices and determine the applicability of regulatory limitations prior to use.*

1.5 *This international standard was developed in accordance with internationally recognized principles on standardization established in the Decision on Principles for the Development of International Standards, Guides and Recommendations issued by the World Trade Organization Technical Barriers to Trade (TBT) Committee.*

## 2. Referenced Documents

### 2.1 ASTM Standards:<sup>2</sup>

<sup>1</sup> This test method is under the jurisdiction of ASTM Committee F23 on Personal Protective Clothing and Equipment and is the direct responsibility of Subcommittee F23.40 on Biological.

Current edition approved June 1, 2017. Published June 2017. Originally approved in 2003. Last previous edition approved in 2010 as F2299/F2299M – 03 (2010). DOI: 10.1520/F2299\_F2299M-03R17.

<sup>2</sup> For referenced ASTM standards, visit the ASTM website, [www.astm.org](http://www.astm.org), or contact ASTM Customer Service at [service@astm.org](mailto:service@astm.org). For *Annual Book of ASTM Standards* volume information, refer to the standard's Document Summary page on the ASTM website.

D1356 Terminology Relating to Sampling and Analysis of Atmospheres

D1777 Test Method for Thickness of Textile Materials

D2905 Practice for Statements on Number of Specimens for Textiles (Withdrawn 2008)<sup>3</sup>

D3776/D3776M Test Methods for Mass Per Unit Area (Weight) of Fabric

E691 Practice for Conducting an Interlaboratory Study to Determine the Precision of a Test Method

F50 Practice for Continuous Sizing and Counting of Airborne Particles in Dust-Controlled Areas and Clean Rooms Using Instruments Capable of Detecting Single Sub-Micrometre and Larger Particles

F328 Practice for Calibration of an Airborne Particle Counter Using Monodisperse Spherical Particles (Withdrawn 2007)<sup>3</sup>

F778 Methods for Gas Flow Resistance Testing of Filtration Media

F1471 Test Method for Air Cleaning Performance of a High-Efficiency Particulate Air Filter System

F1494 Terminology Relating to Protective Clothing

F2053 Guide for Documenting the Results of Airborne Particle Penetration Testing of Protective Clothing Materials

## 3. Terminology

### 3.1 Definitions:

3.1.1 *aerosol, n*—a suspension of a liquid or solid particles in a gas with the particles being in the colloidal size range.

3.1.1.1 *Discussion*—In this test method, aerosols include solid particles having a diameter of 0.1 to 5  $\mu\text{m}$  suspended or dispersed in an airflow at concentrations of less than 102 particles/cm<sup>3</sup>.

3.1.2 *isokinetic sampling, n*—a condition where the velocity of the airflow entering the sampling nozzle is the same as the velocity of the airflow passing around the sampling nozzle.

<sup>3</sup> The last approved version of this historical standard is referenced on [www.astm.org](http://www.astm.org).

3.1.3 *monodispersion, n*—scattering of discrete particles in an airflow where the size is centralized about a specific particle size.

3.1.3.1 *Discussion*—In this test method, the monodispersed particle distribution has a mean diameter size of the aerosol in the 0.1 to 5  $\mu\text{m}$  range, with a coefficient of variation of the mean diameter of  $\pm 10\%$  or less, as certified by the manufacturer.

3.2 For definitions of other protective clothing-related terms used in this test method, refer to Terminology **F1494**.

## 4. Summary of Test Method

4.1 Filtered and dried air is passed through an atomizer to produce an aerosol containing suspended latex spheres.

4.1.1 This aerosol is then passed through a charge neutralizer.

4.1.2 The aerosol is then mixed and diluted with additional preconditioned air to produce a stable, neutralized, and dried aerosol of latex spheres to be used in the efficiency test.

## 5. Significance and Use

5.1 This test method measures the initial filtration efficiency of materials used in medical face masks by sampling representative volumes of the upstream and downstream latex aerosol concentrations in a controlled airflow chamber.

5.2 This test method provides specific test techniques for both manufacturers and users to evaluate materials when exposed to aerosol particle sizes between 0.1 and 5.0  $\mu\text{m}$ .

5.2.1 This test method establishes a basis of efficiency comparison between medical face mask materials.

5.2.2 This test method does not establish a comprehensive characterization of the medical face mask material for a specific protective application.

5.3 This test method does not assess the overall effectiveness of medical face masks in preventing the inward leakage of harmful particles.

5.3.1 The design of the medical face mask and the integrity of the seal of the medical face mask to the wearer's face are not evaluated in this test.

5.4 This test method is not suitable for evaluating materials used in protective clothing for determining their effectiveness against particulate hazards.

5.4.1 In general, clothing design is a significant factor which must be considered in addition to the penetration of particulates.

## 6. Apparatus

6.1 The aerosol test system incorporates the components as shown in **Fig. 1**. A more detailed diagram of test system components and equipment is found in **STP 975**.<sup>4</sup>

### 6.2 Equipment:

6.2.1 Clean, dry compressed air supply,

6.2.2 HEPA filters (2),

6.2.3 Aerosol generator,

6.2.4 Charge neutralizer,

6.2.5 Humidifier,

6.2.6 Test filter holder and duct assembly,

6.2.7 Pressure drop measuring device,

6.2.8 Air flow rate measuring device,

6.2.9 Temperature and relative humidity detectors,

6.2.10 Air blower (optional for negative pressure system), and

6.2.11 Optical particle counters.

## 7. System Preparation and Control

7.1 To test in the aerosol particle size range of 0.1 to 5.0  $\mu\text{m}$ , it is necessary to maintain a very clean inlet air supply. Achieve acceptable levels of background aerosol by passing the atomizing air supply sequentially through a silica gel dryer (for reduction of moisture), a molecular sieve material (for removal of oil vapor), and an ultra-low penetrating aerosol (better than 99.9999 % efficient at 0.6  $\mu\text{m}$ ) filter. Then, supply the air to the test chamber of aerosol generator through pressure regulators of  $\pm 7$  kPa [ $\pm 1$  psi] accuracy. For throttling of the main airflow as well as other flow splitting requirements, use needle valves to maintain adequate flow stability and back pressure. For recommended flow control measurement, see **7.6**. Monitor and record the temperature and relative humidity at the exhaust port of the test chamber. To avoid interference from the test aerosol, take the humidity measurement from the outlet side of the HEPA filter (see **7.6.2**) with an in-line probe.

7.1.1 To provide a stable, reproducible aerosol through the test material that remains constant over the sampling time of the efficiency test, maintain the main test duct and filter medium specimen holder in a vertical orientation to minimize aerosol sedimentation losses.

### 7.2 Aerosol Generation:

7.2.1 The aerosol generator must be capable of a latex sphere count concentrations output of  $10^7$  to  $10^8$  particles/ $\text{m}^3$ . The suspension reservoir must be large enough to sustain a stabilized output greater than 1 h. Two commercially available atomizing techniques that provide these concentrations of the latex spheres are presented in **Figs. 2 and 3**.

7.2.2 As viewed in **Figs. 2 and 3**, these techniques utilize the atomizing of suspended uniform latex spheres from dilute water suspensions. One-liter quantities of these suspensions can be made by diluting the 10 %-by-volume solids of the uniform latex spheres at 1000:1 or greater dilution ratios in deionized, filtered distilled water.

NOTE 1—The suspensions have a three- to six-month usable life. Ideal suspension dilutions are a function of the latex particle size to the aerosol generator droplet size. In order to minimize the atomization of doublets or higher aerosol multiples in the drying process, a recommended latex suspension dilution ratio has been established so that dilution ratios are on the order of 1000:1 to 10 000:1.<sup>5</sup> Other aerosols produced from these atomizers can be classified into monodispersed systems, but for an industrially recognized standard of particle size and composition, the uniform latex spheres are the most reproducible and readily available particles.

<sup>4</sup> Symposium on Gas and Liquid Filtration, *ASTM STP 975*, ASTM, Vol 11, 1986, pp. 141-164.

<sup>5</sup> Raabe, O., "The Dilution of Monodispersed Suspensions for Aerosolization," *American Industrial Hygiene Association Journal*, Vol 29, 1968, pp. 439-443.



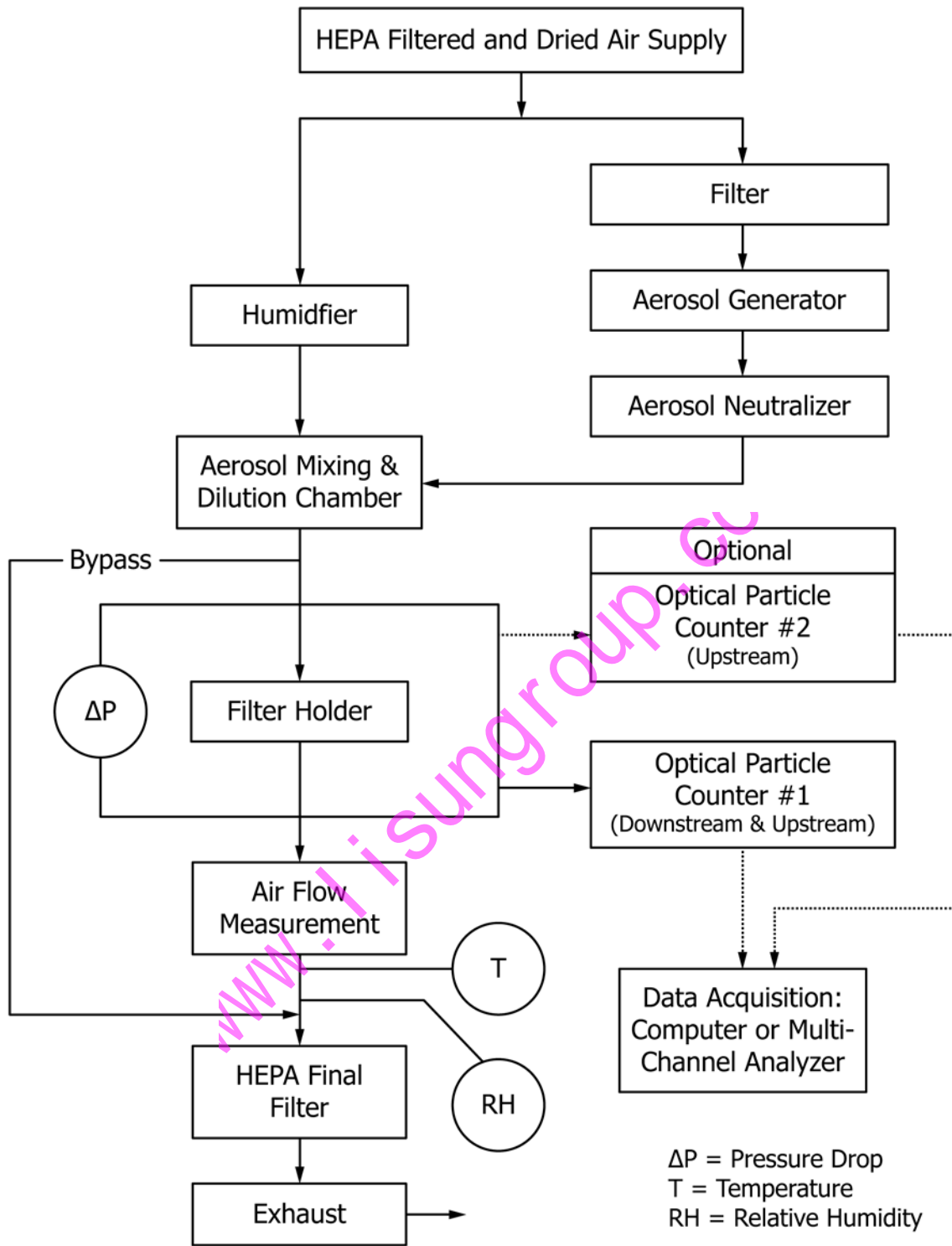

FIG. 1 Schematic of Test Method

7.3 *Aerosol Neutralizer*—This procedure recommends the use of an aerosol charge neutralizer at the inlet of the test

system. This technique generally will ensure aerosol surface charge stability. The aerosol neutralizer can be in the form of a



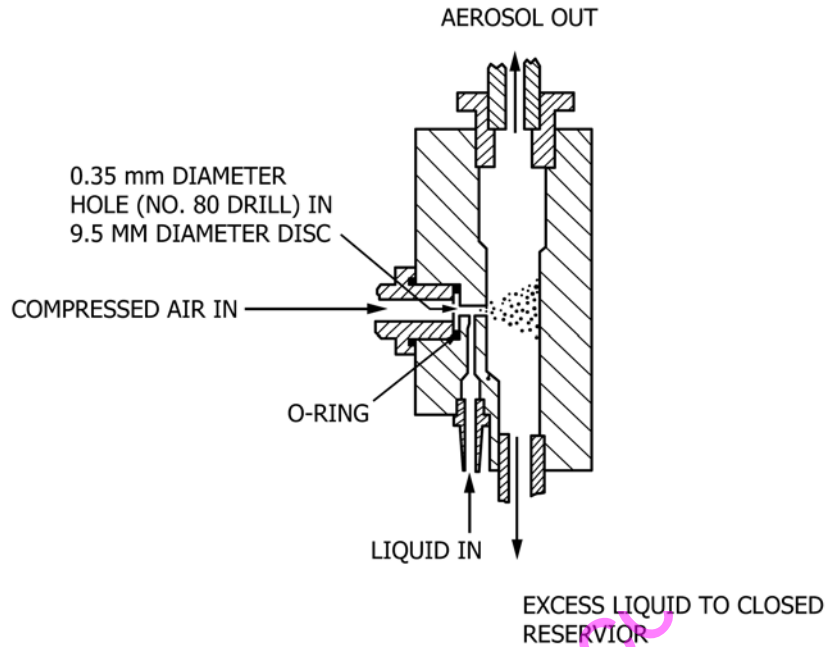

FIG. 2 Atomizer

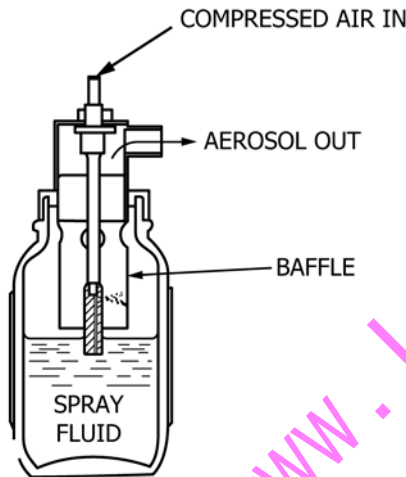

FIG. 3 Collision Atomizer

Complete the aerosol mixing a minimum of 8 duct diameters distance before the inlet sampling probe and the material specimen.

7.5 Material Specimen Holder:

7.5.1 The material specimen holder and test section shall be a continuous straight-walled vessel, interrupted only by the filter medium sample throughout its length. The material specimen holder must provide an uninterrupted airflow, passage without measurable peripheral air leakage. Use a 50- to 150-mm [2- to 6-in.] cross-sectional diameter for the medium sample size. Choose the specimen size to ensure that the test specimen is representative of the overall material and provides enough rigidity to be self-supporting.

NOTE 3—The recommended filter medium cross sections allow face velocities of 0.5 to 25 cm/s [approximately 1 to 50 ft/min] at flow rates of 1 L/min to 1 m<sup>3</sup>/min [approximately 0.035 to 35 ft<sup>3</sup>/min] to be developed in testing.

7.5.2 Introduce the latex aerosol a minimum of 10 duct diameters upstream of the material specimen and at a sufficient distance to provide thorough mixing before the upstream sampling probe.

7.6 Airflow Metering:

7.6.1 Use a positive pressure (compressed air) or a negative pressure (exhaust fan or blower) system for the airflow to the main test chamber. For the application of any of these techniques of airflow measurement and calibration, refer to the standards and practices of the American Society of Mechanical Engineers.

7.6.2 Use a high efficiency particulate aerosol (HEPA)-type filter (99.97 % efficiency on 0.3- $\mu$ m aerosol) upstream of the systems airflow measurement. Size the HEPA-type filter to provide adequate system collection of the exhausting test aerosol.

radioactive decay ionizer. The desired Boltzmann's charge equilibrium for the aerosol has been described.<sup>6</sup> Typically, an ionizing flux of 10<sup>3</sup> mCi/m<sup>3</sup>/s provides the required aerosol neutralization.

NOTE 2—A Krypton 85 source, a Polonium 210 source, or a Corona electrical discharge, A-C source have been found satisfactory for this purpose.

7.4 Aerosol Dilution and Humidity Control—Prior to injection or dispersion of the initial aerosol concentration into the main test chamber, dry or dilute the aerosol with make-up airflow for the final test aerosol concentration as needed. Conduct material testing in a relative humidity range of 30 to 50 % and hold the relative humidity  $\pm 5$  % during a given test.

<sup>6</sup> Liu, B. Y. H. and Piu, D. Y. H., "Electrical Neutralization of Aerosols," *Aerosol Science*, Vol 5, 1974, pp. 465-472.

### 7.7 Pressure Drop Measurement:

7.7.1 Use static pressure taps that are flush with the duct walls at a distance of 1 duct diameter upstream and downstream of the filter medium faces.

7.7.2 With no filter medium in the sample holder, there shall be no measurable pressure loss between the inlet-side and outlet-side pressure taps. Use a pressure-measuring instrument capable of being read to  $\pm 0.025$  cm of water gauge to make this determination.

7.8 *Aerosol Sample Extraction and Transport*—Use geometrically and kinematically identical centerline probes to extract representative aerosols from the inlet and outlet sides of the material specimen test section. Use probes that have a radius of curvature ( $R$ ) of 12 cm or  $R/D$  (Diameter)  $> 20:1$  and present a cross-sectional area of less than 10 % of the cross-sectional area of the test system ducting. Locate the upstream probe 8 duct diameters (minimum) downstream of the aerosol injection point and 2 duct diameters ahead of the material specimen. Locate the downstream probe 3 duct diameters downstream of the filter medium specimen. To minimize aerosol sampling transport line losses due to settling, diffusion, and inertia for the aerosol particle size range of the test method, use the following characteristics of the sampling.

7.8.1 Maintain the sampling line flow in the laminar flow regime; that is, the Reynolds number must be less than 1000. Calculate the Reynolds number in accordance with the following formula:

$$Re\# = \frac{\rho_g V D_1}{\mu_g} \quad (1)$$

where:

- $\rho_g$  = gas density (kg/m<sup>3</sup>),
- $V$  = gas velocity (m/s),
- $D_1$  = inside diameter of sampling lines (m), and
- $\mu_g$  = gas viscosity (kg/m-s).

7.8.2 Limit horizontal sampling line length to less than 100 cm and the total sample transport line to less than 2 m.

7.8.3 Maintain all radius of curvatures to greater than 12 cm.

NOTE 4—Isokinetic aerosol sampling is recommended to minimize probe inlet losses. However, in those cases where isokinetic conditions cannot be met, it is recommended that the operation of these probes be  $\pm 10$  % of isokinetic or that the particle Stokes number at the probe inlet be held to less than 1.0 in order to minimize inertial losses at the probe inlet. It is also recommended that the Reynolds number of the sample flow lines be held to less than 2000. The Stokes number is calculated using the following formula:

$$St\# = \frac{D_p^2 \rho_p V C}{9 \mu_g D_n} \quad (2)$$

where:

- $D_p$  = particle diameter (m),
- $\rho_p$  = particle density (kg/m<sup>3</sup>),
- $V$  = velocity of approach (m/s),
- $\mu_g$  = gas viscosity (kg/m-s),
- $D_n$  = diameter of sampling nozzle (m), and
- $C$  = Cunningham correction factor, which for particles larger than  $1.0 \times 10^{-6}$  m (1  $\mu$ m) is assumed to be 1.0.

NOTE 5—Recommended sampling flow rates for extraction of the

mounting volume are to be less than 10 % of the total test system flow rate.

### 7.9 Aerosol Concentration Counting:

7.9.1 This practice is structured for utilizing automatic, single particle light-scattering counters. For an illustration of the application, calibration, and analyses by these instruments, refer to Practices **F50** and **F328**.

7.9.2 Generally, single particle light-scattering counters measure in the range of 0.1 to 15  $\mu$ m equivalent spherical diameter, with a single particle measurement dynamic range of 50 to 1. These instruments shall be calibrated within the test system, similar to the manufacturer's standard calibration and with the test aerosol as conditioned for the efficiency testing. For efficiencies approaching 99.9 % and greater, a higher test inlet aerosol concentration is usually required to maintain reasonable sampling times at the outlet. If these conditions exceed the suggested coincidence limits for the single particle counters, an inlet dilution at the optical particle counter of the aerosol is required. Achieve inlet dilution by passing some portion of the conditioned inlet aerosol through a HEPA-grade filter and remixing it with the sampled inlet aerosol to the light-scattering particle counter.

7.9.3 Establish accurate dilution ratios in order to specify the exact aerosol sample volume extracted from the inlet flow for aerosol particle counting. Recommended sampling times are on the order of 10 to 60 s. If separate particle counters are used for inlet and outlet aerosol concentrations, they must be calibrated for the aerosol particle size and concentration response needed within the test system.

NOTE 6—The flow rate of the respective optical particle counter must be measured and recorded.

NOTE 7—For test system changes in sampling configuration, that is, alternate upstream and downstream sampling or opening and closing the aerosol flow system, allow a purge time so that 25 sampling line volume changes can occur before counting resumes. (For flow rates of 7 L/min in 6 mm ID samplings, the purge time will be between 10 to 15 s.)

## 8. Number of Downstream/Upstream Sampling Intervals

8.1 The statistical selection of the number of downstream/upstream sampling intervals is based on no specimen present in the filter holder. The test apparatus must meet a  $100 \pm 1$  % penetration average with a coefficient of variation of 3 %. Use the procedure in **8.2** to obtain this selection. Run this procedure twice and use the number of the two results.

### 8.2 Procedure:

8.2.1 Obtain two consecutive downstream/upstream (100 %) penetration sample observations. Calculate their average.

8.2.2 If the average is between 99 and 101 %, proceed to **8.2.4**. If the average is not between 99 and 101 %, run another sample and average it with the previous two samples.

8.2.3 If the new average is between 99 and 101 %, proceed to **8.2.4**. If not, continue this process until  $100 \pm 1$  % penetration is achieved. If 100 % penetration is not achieved, the test apparatus is biased and must be corrected.

8.2.4 Subtract the highest test sample observation from the lowest sample to give the sample range at that certain number of sample observations. Go to **Table 1** for that number of observations and read the adjustment number.

**TABLE 1 Number of Sampling Intervals<sup>A</sup>**

Number of Observations	Adjust if Range is Greater Than
2	4.155
3	4.965
4	5.445
5	5.790
6	6.045
7	6.255
8	6.435
9	6.585
10	6.705
11	6.825
12	6.930
13	7.035
14	7.110
15	7.200
16	7.275
17	7.335
18	7.395
19	7.455
20	7.515

<sup>A</sup> Compare the sample range to the adjustment number.

8.2.5 The adjustment number is the greatest range for a coefficient of variation of 3 % at a penetration of  $100 \pm 1$  % for the specified number of observations.

8.2.6 If the sample range is equal to or less than the adjustment number, the number of sample observations is the number of downstream/upstream sampling intervals for filter testing. If the sampling range is greater than the adjustment number, then another 100 % penetration sampling observation must be run.

8.2.7 If the new penetration is greater or less than the bounds of the past data, a new range is calculated. If, at the new number of sample observations, the new range is greater than the new adjustment number, this process is repeated until the sample range is less than the adjustment number. That number of sample observations is the number of downstream/upstream sampling intervals used for filter testing.

8.2.8 If in a suitable number of intervals it is found that the sample range will always be greater than the adjustment number at 20 observations, then the 100 % penetration data is too variable and action must be taken to correct the particle concentration variability or the particle-counting methodology.

## 9. Material Specimen Selection and Conditioning

9.1 Measure material thickness and unit area weight in accordance with Test Methods **D1777** and **D3776/D3776M**, respectively.

9.2 Apply a sealing force that does not distort or influence the integrity or continuity of the material specimen.

9.3 Use a total of five different material specimens. For statistical-based sampling, choose a number of material specimens as indicated in Practice **D2905** or Methods **F778**.

9.4 If no prior efficiency criteria are available for a specific material, sample to establish a 95 % confidence level about the mean efficiency.

9.5 Precondition each material specimen at the test duct conditions at  $30$  to  $50 \pm 5$  % relative humidity and a temperature of  $21 \pm 3$  °C [ $70 \pm 5$  °F]. Retain all specimens in

an individual closed container to avoid unnecessary contamination and handling prior to testing.

## 10. Test Procedure

### 10.1 System Start-Up:

10.1.1 Set main airflow, dilution airflow, and aerosol generator airflow to test conditions,

10.1.2 Establish airflow controls at required test face velocities as to have air dilution (drying) for aerosol generation of 2:1 or greater. Purge main airflow for 10 to 15 min,

10.1.3 Warm up optical particle counter (OPC) for 15 to 30 min,

10.1.4 After OPC warm-up, check built-in calibration signal or OPC output signal on an oscilloscope for stable gain on photomultiplier tube or other optical detectors.

NOTE 8—This test is conducted with filtered ambient air flowing through the OPC.

10.1.5 Switch the OPC into the main airflow and balance OPC airflow against the main airflow. Observe OPC count data.

### 10.2 Aerosol Drying Verification:

10.2.1 Set up the aerosol generator with a nominal volume of the distilled water to be used in the latex dilutions.

10.2.2 Without a material specimen in the test system, establish the main system airflow and the OPC sampling airflow for the upstream sampling probe.

10.2.3 Sample the upstream and downstream airflow for 1 min each.

10.2.4 Verify complete drying of the aerosol droplets by comparing these counts to counts obtained in **10.1.5**.

10.2.5 Record the relative humidity and the temperature of the airflow.

10.2.6 Run this drying test for approximately 1 h, sampling every 15 min for upstream and downstream counting and record aerosol stability and system relative humidity. Measure the water consumption of the aerosol generator.

10.2.7 Record any dilution airflow and the required air pressure for the aerosol generator.

### 10.3 Aerosol Stability and Zero Efficiency Check:

10.3.1 Fill the aerosol generator with the desired dilution of latex suspension, Without a filter media sample in the test system, close the system and establish the required system airflows.

10.3.2 Stabilize the system airflow with the aerosol suspension for approximately 5 min, then begin successive 1-min upstream and downstream counts for 15 min or until reproducible counts are established. Reproducibility is to meet the sampling criteria in Section 8.

10.3.3 Verify that counting is within a 10 % coincidence of the OPC.

NOTE 9—The OPC channels to be used for counting include channels either side of the maximum count channel that produce a count of 50 % of the maximum channel count or greater.

NOTE 10—There must be a clear minimum channel separation in the OPC between any residue particle distribution and the latex particle distribution in the test aerosol. If necessary, adjust the gain on the OPC to establish this separation.

#### 10.4 Efficiency Test:

10.4.1 Install the material specimen in the test system and re-establish the required airflows.

10.4.2 Monitor the OPC airflow and adjust for the added material specimen  $P$  on the sample flow.

10.4.3 Record the temperature, the relative humidity of the test airflow, and the  $P$  of the filter media.

10.4.4 Sample and record the upstream and downstream aerosol counts for a minimum of five counts at each position using a 1-min sampling time.

NOTE 11—If the downstream count is less than 100, extend the sampling time until 100 counts are obtained. However, do not count longer than 5 min to avoid loading the material specimen.

10.4.5 Monitor the upstream counts; if these counts fall outside the criteria of 8.1, stop the test and check the system for aerosol generation instability.

10.4.6 Average the upstream counts and the downstream counts, then calculate the decimal efficiency by the following definition:

$$\text{Efficiency} = 1 - \text{penetration} = 1 - \frac{(\text{average downstream counts})}{(\text{average upstream counts})}$$

### 11. Calculations

11.1 Prior to the calculations of efficiency, any corrections for background aerosol or apparent background aerosol must be made to the single particle light-scattering counters. If the background count aerosol exceeds 1 % of the outlet concentration, verify the integrity of the light-scattering particle counter, then make corrections through the following equations:

$$\begin{aligned} \text{inlet concentration} &= \text{inlet aerosol count} - \text{inlet background count, and} \\ \text{outlet concentration} &= \text{outlet aerosol count} - \text{inlet background count} \end{aligned}$$

11.2 Calculate the aerosol filtration efficiency for a specific particle size using the following formula:

$$\eta(D_p) = [1 - P(D_p)] 100 \quad (3)$$

where:

$P(D_p)$  = the penetration, and

$P(D_p)$  = (downstream particle concentration) / (upstream particle concentration).

### 12. Report

12.1 Report the following information:

12.1.1 Description of the medical face mask material tested, including its identification, description, manufacturer, lot identification or manufacture date, thickness, basis weight, and an indication of any treatment prior to testing.

12.1.2 A description of the specific challenge particles used, including the size distribution, and percent concentration.

12.1.3 Details for the specific testing conducted including the temperature, relative humidity, exposed specimen area, flowrate, pressure drop, test duration, test sensitivity, and controls used in the testing.

12.1.4 An identification of the aerosol generator, the system flow meters and the particle counters with their current calibrations.

**TABLE 2 Calculated Efficiencies Versus Particle Diameter**

Material Identification	Particle Diameter/ Std. Deviation	Face Velocity	Pressure Drop	Efficiency	
	$D_p$ , $\mu\text{m}$	Std. Deviation	cm/s		kPa
ABC-1	1.0	0.001	10	0.25	95

**TABLE 3 High Variability Range**

	Mean	Standard Deviation	Percent Variation 95 % Confidence Level
Laboratory 1	-0.5.599	0.1328	4.76
Laboratory 2	-0.5.969	0.2241	7.54
Average			6.15

**TABLE 4 Low Variability Range**

	Mean	Standard Deviation	Percent Variation 95 % Confidence Level
Laboratory 3	-1.6429	0.0310	3.80
Laboratory 4	-1.6961	0.0273	3.24
Laboratory 5	-1.7057	0.0272	3.20
Average			3.41

**TABLE 5 Components of Variance**

Source	Component of Variance	Percent of Total Variance	Estimated Standard Deviation
Laboratory	0.067362	66.54	0.259542
Sample	0.012329	12.18	0.111037
Run	0.021543	21.28	0.146776
Total	0.101235		0.318174

**TABLE 6 Components of Variance**

Source	Component of Variance	Percent of Total Variance	Estimated Standard Deviation
Laboratory	0.001088	55.15	0.329880
Sample	0.000386	19.54	0.019636
Run	0.000499	25.31	0.022345
Total	0.001973		0.044420

12.1.5 Test results showing the date tested, number of specimens tested, the location of the specimens from the material or protective clothing sample, and the percent penetration for each particle size on each specimen. Prepare a table listing the calculated efficiencies versus the particle diameter, the face velocity (flow rate) and the pressure drop. See Table 2.

12.1.6 Document results in accordance with Guide F2053.

### 13. Precision and Bias

13.1 No justifiable statement of accuracy can be made since the filtration penetration of a material cannot be established by an independent referee method and since no reproducible standard material specimens exist.

#### 13.2 Precision Analysis:

13.2.1 Filtration penetration mechanisms through flat-sheet fibrous filter material is an exponential function with changes in filter structure (basis weight, fiber size, and/or porosity) and with changes in filter challenge (face velocity, particle size,



particle structure and/or particle electrostatic charge). The statistical distribution function for penetration data is, therefore, approximated as log-normal. This means that the penetration data must be transformed prior to statistical manipulation by taking the natural logarithm of each measured penetration fraction ( $\%P (D_p) / 100$ ). After statistical manipulation, take the antilog of the natural logarithm of the mean penetration (geometric mean) and use this mean penetration to calculate the efficiency. If the antilog of the standard deviation of the transformed data is taken, it is called the geometric standard deviation. If the data are not transformed, then variability is an exponential function with penetration range, creating a situation where the lower the penetration, the greater the variability.

13.2.2 Variability in this section is reported as the percent coefficient of variation of the transformed data at the 95 % confidence level. Means are negative, since the natural logarithms of numbers less than one are negative.

13.2.3 A first multilaboratory experiment, published in STP 975<sup>7</sup> showed that when sphere diameter and face velocity are varied, a high region of variability (large spheres, low face velocity) and a low region of variability (small spheres, high face velocity) exist. Precision statements for each of these regions would provide the range of possible variability for this test.

13.2.4 A second multilaboratory experiment was performed in the format of two three-level completely nested designed experiments. The output from these designs gave the single laboratory/single operator precision, the multilaboratory/single laboratory precision, and also an analysis of the contribution of the separate components of the total variance—laboratory, sample, and run duplication. One experiment was run at the region of high variability, the other was run in the region of low variability. The filters used were of flat fiberglass paper of low variability. Standard deviations presented here are based on  $n$ , not  $(n - 1)$ .

13.3 *Single Laboratory/Single Operator Precision*—Two regimes of variability are presented.

13.3.1 *High Variability Range (Large Spheres, Low Face Velocity)*—The average single laboratory/single operator percent variation of the natural logarithms of the penetration

fraction of this test at a challenge of 2.0- $\mu\text{m}$  sphere diameter and 1-cm/s face velocity is 6.15 % at the 95 % confidence level. See [Table 3](#).

13.3.2 *Low Variability Range (Small Spheres, High Face Velocity)*—The average single laboratory/single operator percent variation of the natural logarithms of the penetration fraction of this test at a challenge of 0.62- $\mu\text{m}$  sphere diameter and 25-cm/s face velocity is 3.41 % at the 95 % confidence level. See [Table 4](#).

13.4 *Multilaboratory-Single Operator Precision*—Two regimes of variability are presented.

13.4.1 *High Variability Range (Large Spheres, Low Face Velocity)*—The multilaboratory/single operator percent variation of the natural logarithms of the penetration fraction of this test between two laboratories is 8.95 % at the 95 % confidence level.

13.4.2 *Low Variability Range (Small Spheres, High Face Velocity)*—The multilaboratory/single operator variation of the natural logarithms of the penetration fraction of this test between three laboratories is 3.94 % at the 95 % confidence level.

13.5 *Analysis of Component of Variance:*

13.5.1 *High Variability Range (Large Spheres, Low Face Velocity)*—Two laboratories ran data on two runs of 25 fiberglass paper filters of low variability challenged with 2.02- $\mu\text{m}$  spheres at 1-cm/s face velocity. Results on the different components of variance of the natural logarithms of the penetration fractions are presented in [Table 5](#).

13.5.2 *Low Variability Range (Small Spheres, High Face Velocity)*—Three laboratories ran data on two runs of 25 fiberglass paper filters of low variability challenged with 0.62- $\mu\text{m}$  spheres at 25-cm/s face velocity. Results on the different components of variance of the natural logarithms of the penetration fraction are presented in [Table 6](#).

13.5.3 *Discussion*—In each of these regimes of high and low variabilities, over 80 % of the variance is attributable to differences between laboratories and their ability to reproduce data.

NOTE 12—An analysis of variance gives a standard deviation based on not  $(n - 1)$ .

## 14. Keywords

14.1 filtration; medical face mask; particle filtration efficiency; particles; particulate

<sup>7</sup> Symposium on Gas and Liquid Filtration, *ASTM STP 973*, ASTM, Vol 1, 1986, pp. 141–151.

*ASTM International takes no position respecting the validity of any patent rights asserted in connection with any item mentioned in this standard. Users of this standard are expressly advised that determination of the validity of any such patent rights, and the risk of infringement of such rights, are entirely their own responsibility.*

*This standard is subject to revision at any time by the responsible technical committee and must be reviewed every five years and if not revised, either reapproved or withdrawn. Your comments are invited either for revision of this standard or for additional standards and should be addressed to ASTM International Headquarters. Your comments will receive careful consideration at a meeting of the responsible technical committee, which you may attend. If you feel that your comments have not received a fair hearing you should make your views known to the ASTM Committee on Standards, at the address shown below.*

*This standard is copyrighted by ASTM International, 100 Barr Harbor Drive, PO Box C700, West Conshohocken, PA 19428-2959, United States. Individual reprints (single or multiple copies) of this standard may be obtained by contacting ASTM at the above address or at 610-832-9585 (phone), 610-832-9555 (fax), or service@astm.org (e-mail); or through the ASTM website (www.astm.org). Permission rights to photocopy the standard may also be secured from the Copyright Clearance Center, 222 Rosewood Drive, Danvers, MA 01923, Tel: (978) 646-2600; http://www.copyright.com/*